

WONDER 抛丸机专用电机

Wonder Electric Motors For Shot Blasting Machine



产品介绍

General Introduction of Products

WONDER
Since 1988

Wonder MS系列、SWEA系列三相异步电机，专为抛丸机等表面处理设备设计。Wonder电机可广泛应用于齿轮箱、风机等通用设备，为抛丸机的运作持续输出强大的动力。MS系列、SWEA系列可实现不同能效等级，充分满足用户的各类应用需求。MS系列、SWEA系列均为铝壳电机，具有结构紧凑、重量轻、外观精美等显著优点。Wonder MS series and SWEA series three-phase induction motors are specially designed for surface treatment equipment such as shot blasting machines. Wonder motors are widely used in gear boxes, fans and other general equipment, to drive the shot blasting machine. MS series and SWEA series can achieve different efficiency level, fully meeting the user's various requirements. The two series adopt aluminum frames, with significant advantages such as compact structure, light weight and delicate appearance.

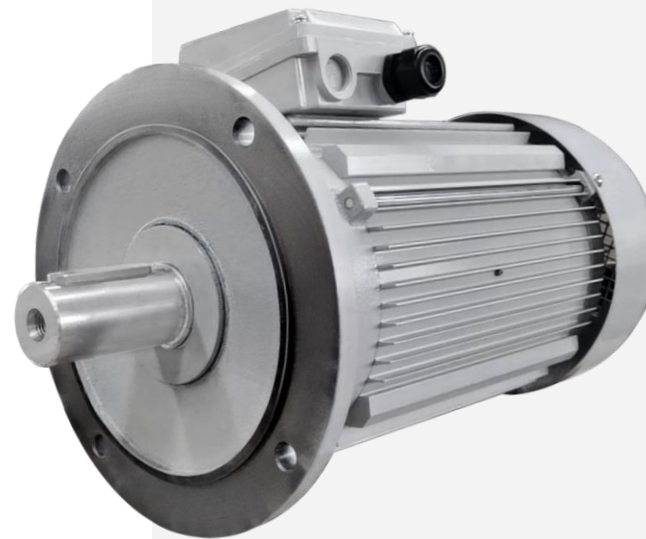

Wonder MS系列三相异步电机
MS Series Three Phase-Induction Motors



主要电气特性

Main Electric Specifications of Motors

防护等级 Protection Class: IP55

绝缘等级 Insulation Class: F

温升等级 Temperature Rise Class: B

工作制 Duty: S1

额定电压 Rated Voltage: 380V

额定频率 Rated Frequency: 50Hz

运行环境温度 Ambient Temperature: -20°C~40°C

运行海拔 Altitude: ≤1000m

冷却方式 Cooling Method: IC411



Wonder SWEA系列三相异步电机
SWEA Series Three-Phase Induction Motors



产品介绍

General Introduction of Products

WONDER
Since 1988



高效节能 High Efficiency

长时间运转的抛丸机对电机的节能能力提出了严格的要求。作为专业高效电机供应商，Wonder自主研发的抛丸机专用电机，在GB及IEC标准中，均实现了同等效率等级下的更高能效。

The long-time running shot blasting machine puts forward strict requirements on the energy saving ability of the motor. As a professional supplier of high efficiency motors, Wonder developed the motors for shot blasting machines, achieving higher efficiency level under the same efficiency class in BOTH GB and IEC standards.

低振动、低噪音 Low Vibration & Low Noise

Wonder电机转子采用半键动态平衡，并采用严密先进的电磁设计，配合后期严格的装配工序，其振动程度符合GB/IEC标准的最优等级，同时也显著降低噪音，创造了更好的工作和使用环境。

The rotor of Wonder motor adopts half key dynamic balance. With advanced electromagnetic design and strict assembly process in the later stage, the vibration level of Wonder motor conforms to the optimal level of GB/IEC standard. We not only significantly reduce noise, but also create a better working environment.

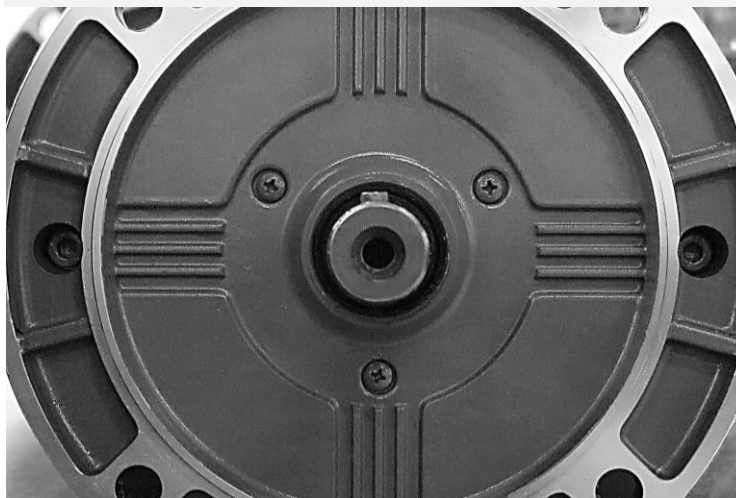

低温升，使用寿命长 Low Temp. Rise & Long Lifespan

Wonder电机的设计充分考虑空气动力学原理，改善空气在电机机壳、风叶、风罩等结构之间的流动情况，保证了电机较低的运行温度，并保护了轴承，显著延长电机使用寿命。

Wonder motors are designed with aerodynamic principles in order to improve the air flow through the frame, fan, and end-shield, ensuring a relatively low operating temperature and protecting the bearings, significantly extending the motor's service life.

Wonder电机广泛应用于各类齿轮箱，组成性能优异的传动系统，从而驱动：

- 斗式提升机
- 螺旋输送机
- 喷砂房的回砂系统等抛丸设备部件。

Wonder motors are used in a wide variety of gearboxes to form an excellent transmission system that drives:

- Bucket elevator
- Screw conveyor
- Other blasting equipment components such as the sand sweeping system of blasting room.

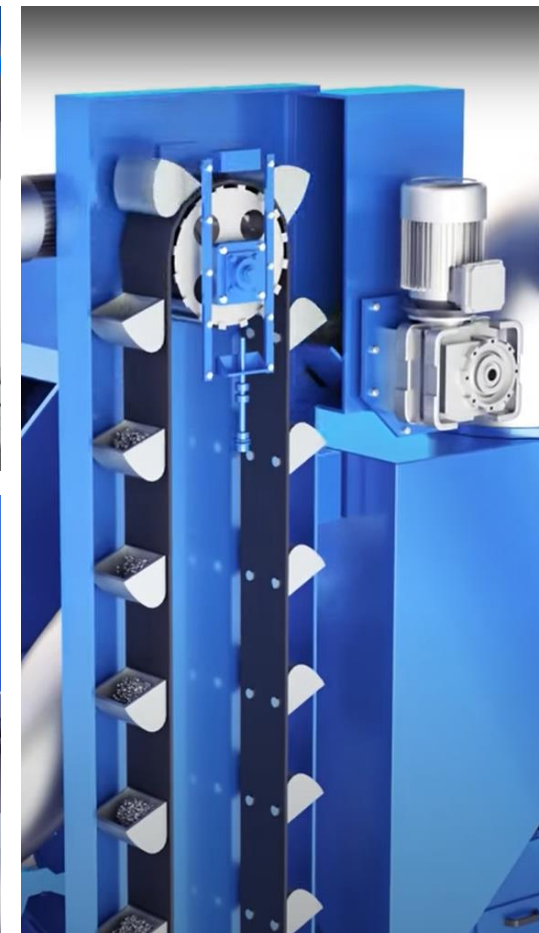
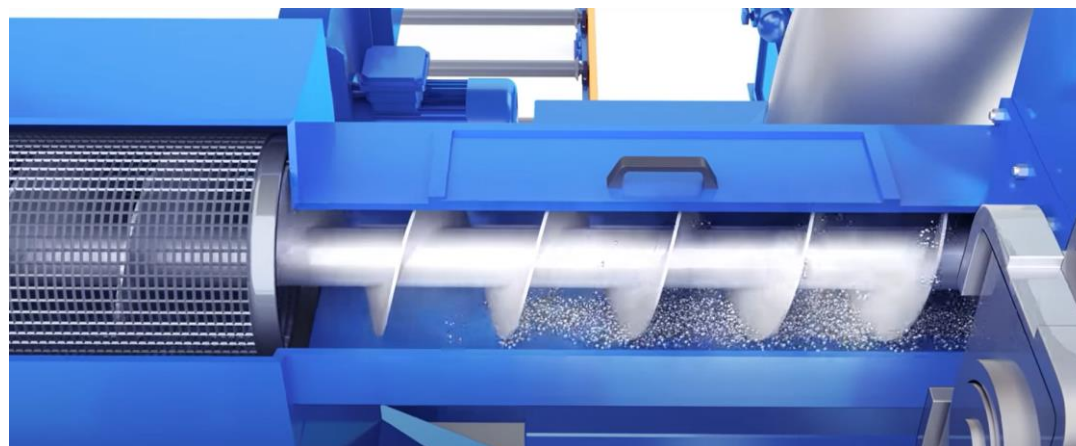
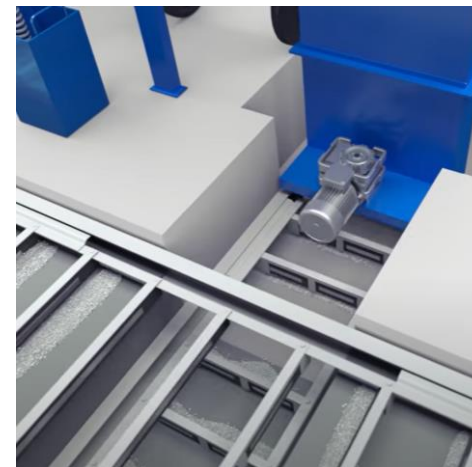
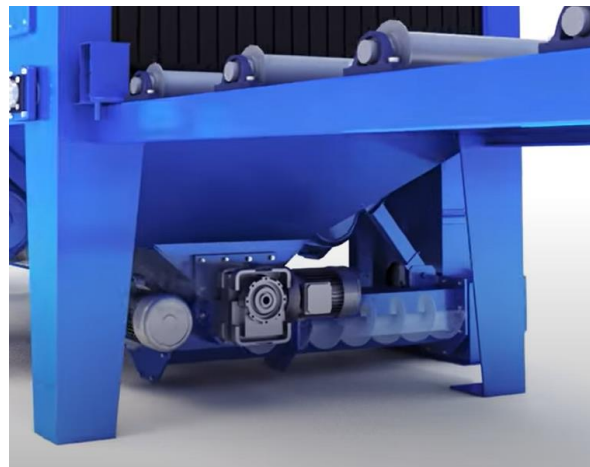

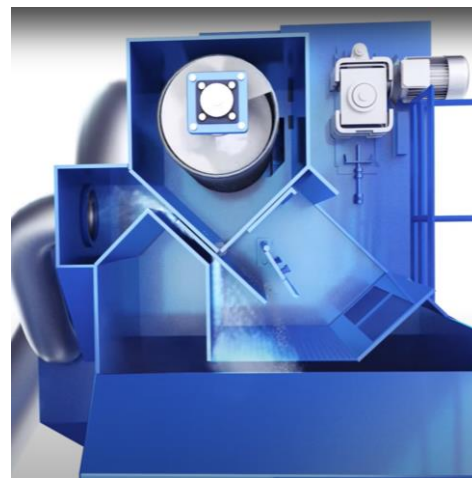
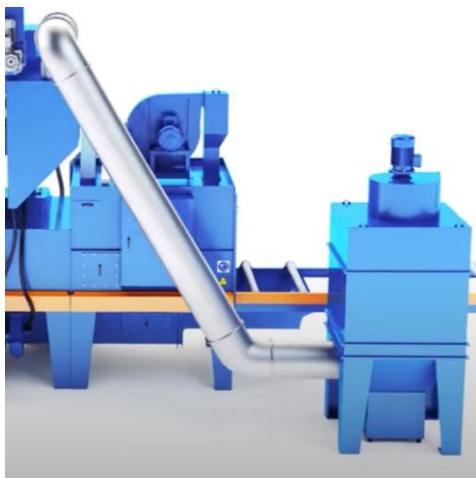

风机、高速叶轮和除尘设备，是抛丸机的重要组成部分。Wonder电机的优异性能，可持续输出强大动力。易于维护、高效稳定等优点，可相应降低用户的使用总成本。

Fans, high speed impellers and dust removal equipment are important parts of shot blasting machine. Wonder motors are capable of sustainable output of strong power with the excellent performance. Technical advantages such as easy maintenance, high efficiency and high stability, can reduce the total cost of users.

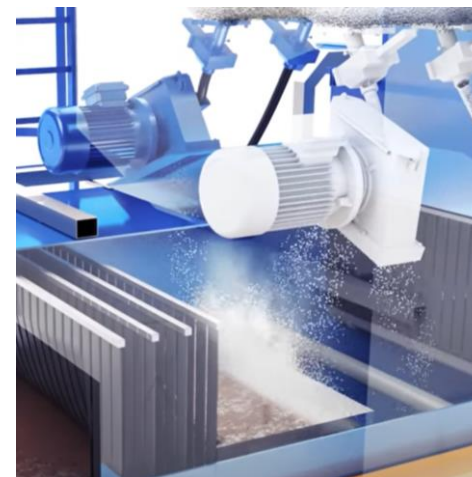

技术参数

Technical Characteristics



型号 Motor Type	功率 Rated Power	电压 Voltage	额定转速 Rated Speed	电流 Full Load Current	效率 Efficiency	功率因数 Power Factor	额定转矩 Rated Torque	堵转电流 额定电流 Locked Rotor Current	堵转转矩 额定转矩 Locked Rotor Torque	最大转矩 额定转矩 Break-down Torque
	kW	V	r/min	A	%	Cosp	N.m	Is/In	Ms/Mn	Mk/Mn
MS132M2	7.5	380	2905	14.9	87.0	0.88	24.6	7.5	2.2	2.4
MS132MC2	11	380	2930	21.6	88.0	0.88	35.8	8.5	2.3	2.5
MS132MD2	15	380	2910	29.2	88.7	0.88	49.2	8.5	2.3	2.5
SWEA132S2-2	7.5	380	2925	14.1	90.1	0.9	24.4	9	2.5	2.8
SWEA132MC2	11	380	2925	20.3	91.2	0.9	35.9	9	2.5	2.8
SWEA132MD2	15	380	2925	27.6	91.9	0.9	48.5	9	2.5	2.8

产品安装尺寸图

Mounting and Overall Dimensions

WONDER
Since 1988

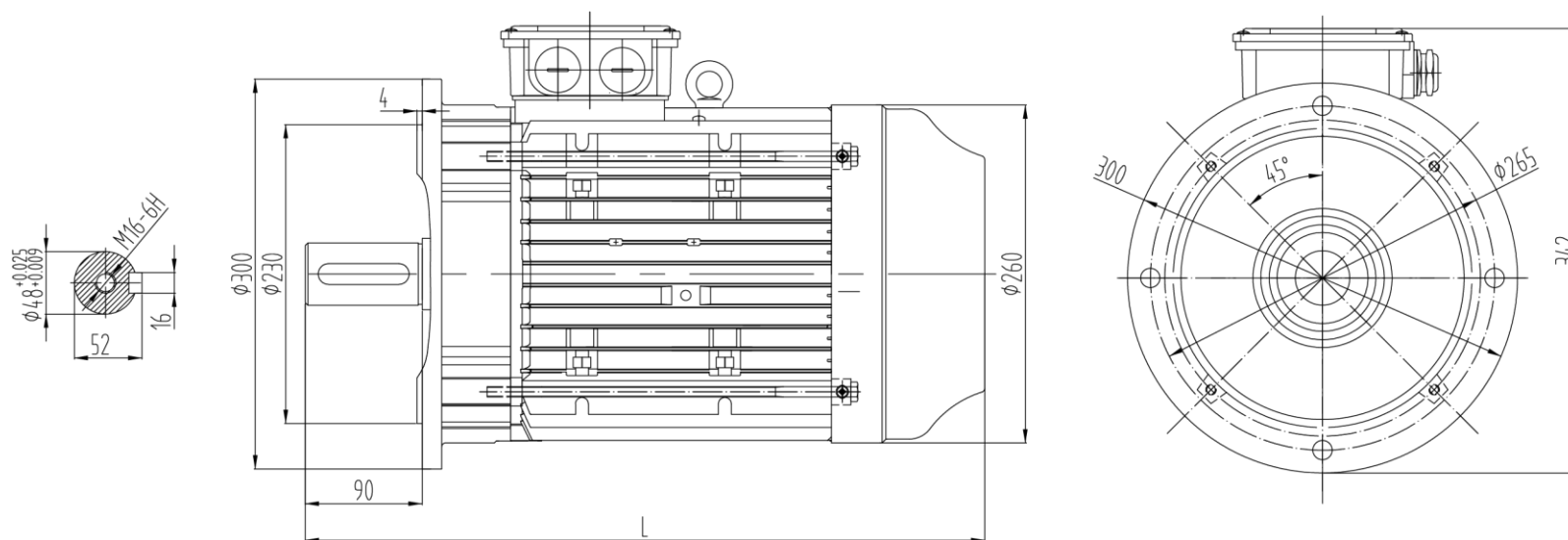
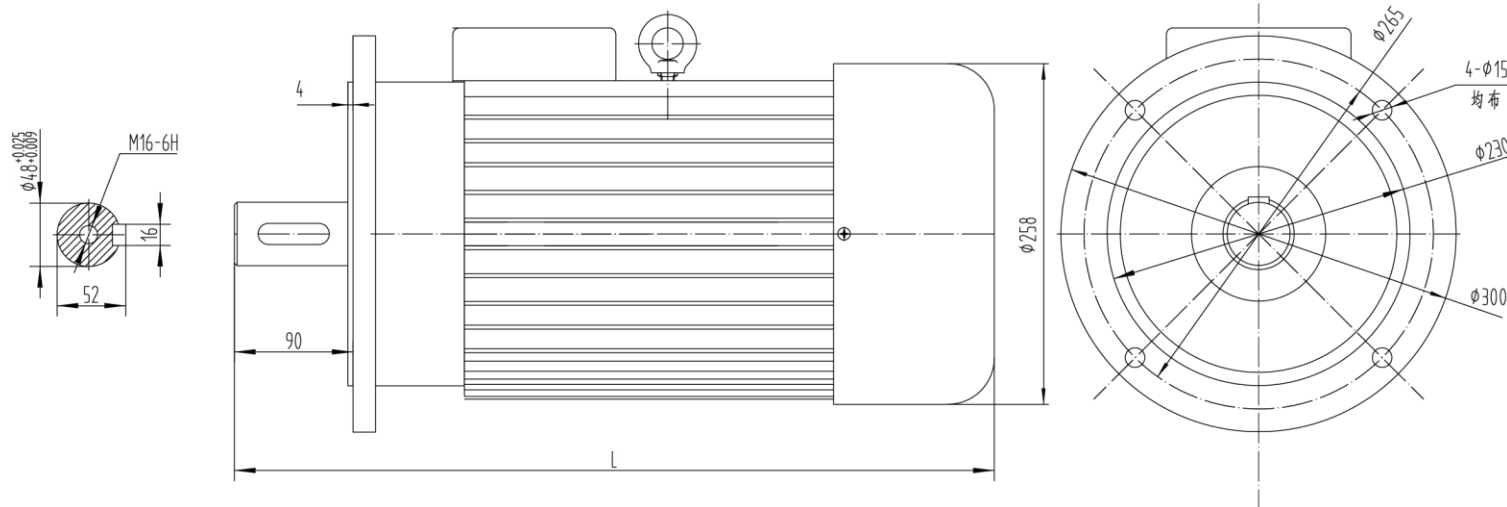

功率 Output Power	L
7.5kW	495
11kW	575
15kW	575

功率 Output Power	L
7.5kW	495
11kW	533
15kW	533

了解更多信息，欢迎联系WONDER!

福建万达电机有限公司 Wonder Electric (Fu' an)

联系电话/Tel: +86-593-6379666 6379988

企业邮箱/Email: wonder@dayu-casting.com

网站/Web: www.wonder-cn.com

地址/Add: 福建省福安电机电器工业区兴达路239号/No.239 Xingda Rd, Electrical Machinery And Appliances Zone, Fu' an, Fujian ,China

福州万德电气有限公司 Wonder Electric (Fuzhou)

联系电话/Tel: +86-591-83998899

企业邮箱/Email: wonder@wonderfz.com

网站/Web: www.wonderfz.com

地址/Add: 福建省福州市经济开发区长安投资区长洋路120号/No. 120, Changyang Rd, Chang An Investment District, Fuzhou Development Zone, Fujian, China