

WONDER 萬德 始於1988

In Synchronization with the Future

ISO14001 ISO9001 ISO45001   CE  RoHS  SASO  TUV  SESCO  UL  UL

万德电气 WST 系列

超超高效三相永磁同步电机 (IE5·IE4)

WST 系列

超超高效三相永磁同步电机



产品概述：

万德电气 WST 系列永磁同步电机采用以钕铁硼等高矫顽力、高渗磁感应密度的稀土永磁材料制作而成的内置式永磁磁钢，可在保证高效的同时，提供更高的功率密度，在过载情况下，电机同样能展现过硬的电气特性。

WST 系列电机实现了降机座，同时其输出功率可保证不变，电机所需的安装空间将大大节省。该系列产品在各转速下均可输出恒转矩，甚至在低转速下其效率亦可优于异步感应电机。

WST 系列永磁同步电机已实现国家一级、二级能效（IE5、IE4）。

WST 系列永磁电机配备东芝变频器，可应用于潮湿、粉尘和振动场合。变频器安装灵活，广泛应用于水泵、风机等通用设备，以及对防护等级有较高要求的电气传动场合。

万德电气永磁电机，具备多转速运作、低速精确控制、低噪音、结构紧凑等一系列显著的技术优势。

主要应用：

冷却塔、袋滤器、造纸机械、纺织机械、传送工具、泵类、挤压机、空压机、风机、可替代部分直流电机等。

万德电气 WST 同步永磁电机电气特性：

- 变频调速恒转矩
- 无转子损耗，低温升，高效，可实现一级、二级能效
- 过载情况下，效率性能同样表现卓越
- 高转矩密度，高功率密度，高功率因数
- 无感控制（无需使用编码器）
- 无滑差，同步转速，实现精确的转速控制
- 在弱磁调速状态下保持功率恒定
- 过载能力强、特性硬
- 变速范围广，支持电机直驱

主要技术参数：

- 机座：71-355
- 功率范围：0.55-400KW
- 额定转速：4500/3600/3000/1800/1500 转 / 分钟
- 防护等级：IP55
- 绝缘等级：F 级
- 温升等级：B 级
- 连续工作制：S1
- 电压：400V
- 运行环境温度：-20°C ~40°C
- 运行海拔：≤ 1000 米
- 按需求可定制 IE5 电机

WST 系列超超高效三相永磁同步电机技术数据 (1/5)

型号	机座号	额定转速 (r/m)	额定功率 P_n (kW)	额定转矩 M_n (Nm)	峰值扭矩 M_{pk} (Nm)	电势常数 K_e (Vs)	转矩常数 K_t (Nm/A)	额定转速 反电势 E_n (V)	额定电流 I_n (A)	效率 ($\eta\%$)	转动惯量 $J(\text{kg}^2)$	重量 kg
4500 转 / 分钟 (6 极) 225 赫兹												
WST71-4500-1.1	71	4500	1.1	2.3	7.0	0.571	0.989	273.5	2.4	89.1	0.000487	5.0
WST71-4500-1.5	71	4500	1.5	3.2	9.6	0.577	0.999	273.5	3.2	90.6	0.000603	5.7
WST71-4500-2.2	71	4500	2.2	4.7	14.0	0.585	1.013	273.5	4.6	91.7	0.000778	6.5
WST71-4500-3.0	71	4500	3.0	6.4	19.1	0.605	1.048	273.5	6.1	92.6	0.000953	7.4
WST90-4500-3.0	90L	4500	3.0	6.4	19.1	0.623	1.060	288	6.0	91.8	0.002583	10.5
WST90-4500-4.0	90L	4500	4.0	8.5	25.5	0.623	1.060	288	8.0	92.4	0.003194	12.6
WST90-4500-5.5	90L	4500	5.5	11.7	35.0	0.623	1.060	288	11.0	93.0	0.003806	14.7
WST90-4500-7.5	90L	4500	7.5	15.9	47.8	0.623	1.060	288	15.0	93.5	0.004417	17.8
3600 转 / 分钟 (6 极) 180 赫兹												
WST71-3600-0.75	71	3600	0.75	2.0	6.0	0.732	1.268	273.5	1.6	88.3	0.000545	5.0
WST71-3600-1.1	71	3600	1.1	2.9	8.8	0.732	1.268	273.5	2.3	89.9	0.000662	5.7
WST71-3600-1.5	71	3600	1.5	4.0	11.9	0.732	1.268	273.5	3.4	90.9	0.000837	6.3
WST71-3600-2.2	71	3600	2.2	5.8	17.5	0.732	1.268	273.5	4.5	91.9	0.00101	7.0
WST90-3600-2.2	90L	3600	2.2	5.8	17.5	0.766	1.327	288	4.4	91.7	0.002379	10.5
WST90-3600-3.0	90L	3600	3.0	8.0	23.9	0.766	1.327	288	6.0	92.4	0.00299	12.6
WST90-3600-4.0	90L	3600	4.0	10.6	31.8	0.766	1.327	288	8.0	92.9	0.003806	14.7
WST90-3600-5.5	90L	3600	5.5	14.6	43.8	0.766	1.327	288	11.0	93.4	0.004417	16.8
WST112-3600-5.5	112M	3600	5.5	14.6	43.8	0.766	1.327	288	11.0	93.0	0.008223	24.0
WST112-3600-7.5	112M	3600	7.5	19.9	59.7	0.766	1.327	288	15.0	93.7	0.010062	27.3
WST112-3600-11	112M	3600	11	29.2	87.5	0.766	1.327	288	21.3	94.4	0.013743	31.5
WST112-3600-15	112M	3600	15	39.8	119	0.766	1.327	288	29.0	94.9	0.018571	35.0
WST132-3600-15	132M	3600	15	39.8	119	0.779	1.350	294	29.5	94.1	0.026811	54.0
WST132-3600-18.5	132M	3600	18.5	49.4	147	0.779	1.350	294	35.9	94.8	0.031426	61.0
WST132-3600-22	132M	3600	22	58.4	175	0.779	1.350	294	42.6	95.0	0.03604	68.0
WST132-3600-30	132M	3600	30	79.6	239	0.779	1.350	294	57.9	95.4	0.040528	75.0
WST160-3600-22	160M	3600	22	58.0	140	0.881	1.526	332	40.0	94.3	0.05632	107
WST160-3600-30	160M	3600	30	80.0	191	0.881	1.526	332	54.0	94.7	0.074611	117
WST160-3600-37	160M	3600	37	98.0	235	0.878	1.521	331	67.0	95.0	0.090316	127
WST180-3600-37	180M	3600	37	98.0	236	0.894	1.549	337	67.0	94.1	0.105229	141
WST180-3600-45	180M	3600	45	119	287	0.916	1.586	345	80.5	94.6	0.120464	149
WST180-3600-55	180L	3600	55	146	350	0.899	1.558	339	96.5	94.9	0.139443	159
WST200-3600-55	200L	3600	55	146	350	0.939	1.627	354	96.5	95.5	0.243556	193
WST200-3600-75	200L	3600	75	199	478	0.950	1.646	358	130	95.9	0.308539	219

WST 系列超超高效三相永磁同步电机技术数据 (2/5)

型号	机座号	额定转速 (r/m)	额定功率 P_n (kW)	额定转矩 M_n (N _m)	峰值转矩 M_{pk} (N _m)	电势常数 K_e (V _s)	转矩常数 K_t (N _m /A)	额定转速 反电势 E_n (V)	额定电流 I_n (A)	效率 (η%)	转动惯量 J (kg ²)	重量 kg
3600 转 / 分钟 (8 极) 240 赫兹												
WST225-3600-75	225M	3600	75	199	478	0.918	1.590	346	137	95.6	0.412735	251
WST225-3600-90	225M	3600	90	239	534	0.924	1.600	348	163	95.9	0.467087	271
WST225-3600-110	225M	3600	110	292	701	0.942	1.632	355	195	96.2	0.548615	301
WST250-3600-110	250M	3600	110	292	701	0.921	1.595	347	204	96.0	0.581501	391
WST250-3600-132	250M	3600	132	350	840	0.924	1.600	348	244	96.2	0.661823	420
WST280-3600-132	280M	3600	132	350	840	0.939	1.627	354	238	96.2	1.294743	480
WST280-3600-160	280M	3600	160	424	1018	0.934	1.618	352	290	96.3	1.487119	517
WST280-3600-180	280M	3600	180	478	1147	0.937	1.623	353	323	96.3	1.61537	541
WST280-3600-200	280M	3600	200	531	1274	0.937	1.623	353	354	96.5	1.74362	565
WST315-3600-132	315S	3600	132	350	770	0.926	1.604	349	241	96.2	226.26	737
WST315-3600-160	315S	3600	160	424	935	0.921	1.595	347	294	96.3	244.04	778
WST315-3600-180	315S	3600	180	478	1052	0.932	1.613	351	325	96.3	252.93	794
WST315-3600-200	315M/L	3600	200	531	1168	0.937	1.623	353	364	96.5	261.82	835
WST315-3600-220	315M/L	3600	220	584	1285	0.937	1.623	353	395	96.5	273.67	863
WST315-3600-250	315M/L	3600	250	663	1459	0.934	1.618	352	450	96.5	285.52	885
WST315-3600-315	315M/L	3600	315	836	1839	0.926	1.604	349	568	96.6	315.45	962
WST315-3600-355	315M/L	3600	355	942	2043	0.934	1.618	352	632	96.6	341.82	1007
WST315-3600-400	315M/L	3600	400	1061	2334	0.937	1.623	353	712	96.6	371.45	1076

WST 系列超超高效三相永磁同步电机技术数据 (3/5)

型号	机座号	额定转速 (r/m)	额定功率 P_n (kW)	额定转矩 M_n (Nm)	峰值扭矩 M_{pk} (Nm)	电势常数 K_e (V_s)	转矩常数 K_t (Nm/A)	额定转速 反电势 E_n (V)	额定电流 I_n (A)	效率 ($\eta\%$)	转动惯量 J (kg^2)	重量 kg
3000 转 / 分钟 (6 极) 150 赫兹												
WST71-3000-0.75	71	3000	0.75	2.4	7.2	0.861	1.491	273.5	1.6	89.1	0.000545	5.0
WST71-3000-1.1	71	3000	1.1	3.5	40.5	0.861	1.491	273.5	2.3	90.6	0.000662	5.4
WST71-3000-1.5	71	3000	1.5	4.8	14.3	0.861	1.491	273.5	3.3	91.3	0.000837	6.3
WST71-3000-2.2	71	3000	2.2	7.0	21.0	0.861	1.491	273.5	4.6	92.0	0.00101	7.0
WST90-3000-2.2	90L	3000	2.2	7.0	21.0	0.918	1.590	288	4.4	91.5	0.002379	10.5
WST90-3000-3.0	90L	3000	3.0	9.6	28.7	0.918	1.590	288	6.0	92.1	0.00299	12.6
WST90-3000-4.0	90L	3000	4.0	12.7	38.2	0.918	1.590	288	8.0	92.5	0.003806	14.7
WST90-3000-5.5	90L	3000	5.5	17.5	52.5	0.918	1.590	288	11.0	93.0	0.004417	16.8
WST112-3000-5.5	112M	3000	5.5	17.5	52.5	0.918	1.590	288	11.0	93.0	0.008784	24.0
WST112-3000-7.5	112M	3000	7.5	23.9	71.6	0.918	1.590	288	14.9	93.8	0.011233	27.3
WST112-3000-11	112M	3000	11	35.0	105	0.918	1.590	288	21.5	94.4	0.014969	31.5
WST112-3000-15	112M	3000	15	47.8	143	0.918	1.590	288	29.1	94.8	0.019211	35.0
WST132-3000-15	132M	3000	15	47.8	143	0.936	1.662	294	29.2	94.7	0.029118	54.0
WST132-3000-18.5	132M	3000	18.5	58.9	177	0.936	1.662	294	36.0	95.0	0.033733	61.0
WST132-3000-22	132M	3000	22	70.0	210	0.936	1.662	294	42.6	95.2	0.038348	68.0
WST132-3000-30	132M	3000	30	95.4	286	0.936	1.662	294	58.0	95.5	0.042822	75.0
WST160-3000-22	160M	3000	22	70.0	168	1.061	1.836	333	39.5	94.8	0.087701	113
WST160-3000-30	160M	3000	30	96.0	229	1.067	1.848	335	53.0	95.2	0.100791	120
WST160-3000-37	160M	3000	37	118	283	1.080	1.870	339	66.0	95.4	0.129955	129
WST180-3000-37	180M	3000	37	118	283	13.070	1.853	336	65.5	95.0	0.109022	143
WST180-3000-45	180M	3000	45	143	344	13.070	1.853	332	81.0	95.3	0.124257	151
WST180-3000-55	180L	3000	55	175	420	1.086	1.881	341	97.0	95.5	0.151597	164
WST200-3000-55	200L	3000	55	175	420	1.121	1.942	352	97.0	95.8	0.267882	203
WST200-3000-75	200L	3000	75	239	574	1.118	1.936	351	134	96.0	0.341053	230
3000 转 / 分钟 (8 极) 200 赫兹												
WST225-3000-75	225M	3000	75	239	574	1.108	1.920	348	136	96.0	0.467087	271
WST225-3000-90	225M	3000	90	287	688	1.099	1.903	345	164	96.2	0.521439	291
WST225-3000-110	225M	3000	110	350	840	1.102	1.909	346	198	96.3	0.602967	321
WST250-3000-110	250M	3000	110	350	770	1.108	1.920	348	202	96.0	0.677888	426
WST250-3000-132	250M	3000	132	420	924	1.108	1.920	348	243	96.2	0.822468	461
WST280-3000-132	280M	3000	132	420	924	1.143	1.980	359	233	96.2	1.455056	510
WST280-3000-160	280M	3000	160	509	1120	1.131	1.958	355	286	96.4	1.679495	553
WST280-3000-180	280M	3000	180	573	1261	1.150	1.991	361	313	96.5	1.807746	578
WST280-3000-200	280M	3000	200	637	1402	1.124	1.947	353	360	96.6	2.033928	608
WST315-3000-132	315S	3000	132	420	840	1.105	1.914	347	242	96.2	244.04	777
WST315-3000-160	315S	3000	160	509	1018	1.127	1.953	354	289	96.3	267.74	830
WST315-3000-180	315S	3000	180	573	1146	1.118	1.936	351	325	96.3	276.63	846
WST315-3000-200	315M/L	3000	200	637	1401	1.127	1.953	354	358	96.5	288.49	894
WST315-3000-220	315M/L	3000	220	700	1540	1.118	1.936	351	394	96.5	300.34	922
WST315-3000-250	315M/L	3000	250	796	1751	1.118	1.936	351	449	96.5	315.15	950
WST315-3000-315	315M/L	3000	315	1003	2207	1.121	1.942	352	563	96.6	356.63	1048
WST315-3000-355	315M/L	3000	355	1130	2451	1.121	1.942	352	634	96.7	383.30	1099
WST315-3000-400	315M/L	3000	400	1273	2801	1.121	1.942	352	712	96.8	418.86	1181

WST 系列超超高效三相永磁同步电机技术数据 (4/5)

型号	机座号	额定转速 (r/m)	额定功率 P_n (kW)	额定转矩 M_n (Nm)	峰值扭矩 M_{pk} (Nm)	电势常数 K_e (V_s)	转矩常数 K_t (N_m/A)	额定转速 反电势 E_n (V)	额定电流 I_n (A)	效率 ($\eta\%$)	转动惯量 J (kg^2)	重量 kg
1800 转 / 分钟 (6 极) 90 赫兹												
WST71-1800-0.55	71	1800	0.55	2.9	8.8	1.452	2.515	273.5	1.2	87.3	0.000603	5.0
WST71-1800-0.75	71	1800	0.75	4.0	11.9	1.452	2.515	273.5	1.6	88.5	0.000778	5.7
WST71-1800-1.1	71	1800	1.1	5.8	17.5	1.452	2.515	273.5	2.3	89.7	0.00101	6.5
WST71-1800-1.5	71	1800	1.5	8.0	23.9	1.452	2.515	273.5	3.1	90.3	0.00113	7.4
WST90-1800-1.5	90L	1800	1.5	8.0	23.9	1.525	2.640	288	3.0	91.2	0.003194	10.5
WST90-1800-2.2	90L	1800	2.2	11.7	35.0	1.525	2.640	288	4.4	91.7	0.003806	12.6
WST90-1800-3.0	90L	1800	3	15.9	47.7	1.525	2.640	288	6.0	92.3	0.004621	14.7
WST90-1800-4.0	90L	1800	4	21.2	63.7	1.525	2.640	288	8.0	92.4	0.005436	17.8
WST112-1800-4.0	112M	1800	4	21.2	63.7	1.525	2.640	288	8.0	92.0	0.011233	24.0
WST112-1800-5.5	112M	1800	5.5	29.2	87.5	1.525	2.640	288	11.0	92.8	0.013743	27.3
WST112-1800-7.5	112M	1800	7.5	39.8	119	1.525	2.640	288	14.9	93.4	0.01743	31.5
WST112-1800-11	112M	1800	11	58.4	175	1.525	2.640	288	21.6	93.6	0.017997	35.0
WST132-1800-11	132M	1800	11	58.4	175	1.564	2.708	294	21.6	94.3	0.033733	54.0
WST132-1800-15	132M	1800	15	79.6	239	1.564	2.708	294	29.3	94.7	0.040528	61.0
WST132-1800-18.5	132M	1800	18.5	98.1	294	1.564	2.708	294	36.1	94.8	0.042822	68.0
WST160-1800-18.5	160M	1800	18.5	98.0	235	1.762	3.052	332	33.5	94.6	0.074611	117
WST160-1800-22	160M	1800	22	117	281	1.757	3.043	331	39.5	94.9	0.087701	124
WST160-1800-30	160L	1800	30	159	382	1.762	3.052	332	53.5	95.3	0.116866	145
WST180-1800-30	180M	1800	30	159	382	1.805	3.127	340	54	94.9	0.13565	155
WST180-1800-37	180L	1800	37	196	472	1.767	3.061	333	66	95.4	0.163024	169
WST180-1800-45	180L	1800	45	239	574	1.778	3.08	335	81.5	95.6	0.197304	184
WST200-1800-45	200L	1800	45	239	574	1.858	3.218	350	80	95.4	0.308539	219
WST200-1800-55	200L	1800	55	292	701	1.858	3.218	350	98	95.7	0.357181	235
1800 转 / 分钟 (8 极) 120 赫兹												
WST225-1800-55	225M	1800	55	292	701	1.858	3.218	350	99	95.7	0.521439	291
WST225-1800-75	225M	1800	75	398	955	1.874	3.245	353	134	96.0	0.670907	346
WST250-1800-75	250M	1800	75	398	955	1.847	3.199	348	137	96.0	0.677888	426
WST250-1800-90	250M	1800	90	478	1147	1.847	3.199	348	165	96.2	0.774275	461
WST280-1800-110	280M	1800	110	584	1402	1.884	3.264	355	194	96.3	1.74362	565
WST280-1800-132	280M	1800	132	700	1680	1.874	3.245	353	234	96.4	2.033928	608
WST280-1800-160	280M	1800	160	849	2038	1.879	3.254	354	284	96.6	2.352811	681
WST315-1800-110	315S	1800	110	584	1285	1.884	3.264	355	195	96.3	244.28	810
WST315-1800-132	315S	1800	132	700	1540	1.874	3.245	353	234	96.4	265.02	854
WST315-1800-160	315S	1800	160	849	1868	1.879	3.254	354	287	96.6	294.65	921
WST315-1800-180	315M/L	1800	180	955	2101	1.852	3.208	349	320	96.7	321.08	970
WST315-1800-200	315M/L	1800	200	1061	2334	1.895	3.282	357	354	96.7	332.93	993
WST315-1800-220	315M/L	1800	220	1167	2567	1.890	3.273	356	390	96.7	344.78	1020
WST315-1800-250	315M/L	1800	250	1326	2917	1.890	3.273	356	444	96.7	374.41	1083
WST315-1800-315	315M/L	1800	315	1671	3676	1.895	3.282	357	560	96.9	415.89	1181

WST 系列超超高效三相永磁同步电机技术数据 (5/5)

型号	机座号	额定转速 (r/m)	额定功率 P_n (kW)	额定转矩 M_n (N·m)	峰值扭矩 M_{pk} (N·m)	电势常数 K_e (V _s)	转矩常数 K_t (N·m/A)	额定转速 反电势 E_n (V)	额定电流 I_n (A)	效率 (η %)	转动惯量 J (kg ²)	重量 kg
1500 转 / 分钟 (6 极) 75 赫兹												
WST71-1500-0.55	71	1500	0.55	3.5	10.5	1.742	3.017	273.5	1.2	86.7	0.000603	5.0
WST71-1500-0.75	71	1500	0.75	4.8	14.4	1.742	3.017	273.5	1.6	88.1	0.000778	5.7
WST71-1500-1.1	71	1500	1.1	7.0	21.0	1.742	3.017	273.5	2.3	89.1	0.00101	6.5
WST71-1500-1.5	71	1500	1.5	9.6	28.8	1.742	3.017	273.5	3.1	89.1	0.00113	7.4
WST90-1500-1.5	90L	1500	1.5	9.6	28.8	1.837	3.180	288	3.0	91.0	0.003194	10.5
WST90-1500-2.2	90L	1500	2.2	14.0	42.0	1.837	3.180	288	4.4	91.6	0.003806	12.6
WST90-1500-3.0	90L	1500	3	19.1	57.3	1.837	3.180	288	6.0	92.1	0.004621	14.7
WST90-1500-4.0	90L	1500	4	25.5	76.4	1.837	3.180	288	8.0	92.2	0.005436	17.8
WST112-1500-4.0	112M	1500	4	25.5	76.4	1.837	3.180	288	8.0	92.2	0.011233	24.0
WST112-1500-5.5	112M	1500	5.5	35.0	105	1.837	3.180	288	11.0	92.4	0.013743	27.3
WST112-1500-7.5	112M	1500	7.5	47.8	143	1.837	3.180	288	15.0	92.9	0.017423	31.5
WST112-1500-11	112M	1500	11	70.0	210	1.837	3.180	288	22.0	92.9	0.019211	35.0
WST132-1500-11	132M	1500	11	70.0	210	1.887	3.245	294	21.6	94.3	0.033733	54.0
WST132-1500-15	132M	1500	15	95.5	287	1.887	3.245	294	29.4	94.5	0.040528	61.0
WST132-1500-18.5	132M	1500	18.5	118	353	1.887	3.245	294	36.2	94.6	0.042822	68.0
WST160-1500-18.5	160M	1500	18.5	118	283	2.115	3.663	332	33	94.8	0.087701	125
WST160-1500-22	160M	1500	22	140	336	2.115	3.663	331	39.5	94.9	0.100791	132
WST160-1500-30	160L	1500	30	191	420	2.134	3.696	335	53	95.2	0.129956	152
WST180-1500-30	180M	1500	30	191	458	2.166	3.751	340	54	94.9	0.13565	155
WST180-1500-37	180L	1500	37	236	565	2.166	3.751	341	64.5	95.2	0.163024	169
WST180-1500-45	180L	1500	45	287	688	2.166	3.751	343	81	95.4	0.197304	184
WST200-1500-45	200L	1500	45	287	688	2.229	3.861	350	79	95.4	0.341053	230
WST200-1500-55	200L	1500	55	350	840	2.261	3.916	355	94.6	95.7	0.397701	245
1500 转 / 分钟 (8 极) 100 赫兹												
WST225-1500-55	225M	1500	55	350	840	2.229	3.861	350	98.6	95.7	0.575791	311
WST225-1500-75	225M	1500	75	478	1146	2.261	3.916	355	132	96.0	0.752435	376
WST250-1500-75	250M	1500	75	478	1051	2.216	3.838	348	137	96.0	0.677888	426
WST250-1500-90	250M	1500	90	573	1261	2.267	3.926	356	161	96.2	0.790339	467
WST280-1500-110	280M	1500	110	700	1540	2.248	3.894	353	196.4	96.3	2.033928	608
WST280-1500-132	280M	1500	132	840	1848	2.248	3.894	353	234	96.4	2.288686	669
WST280-1500-160	280M	1500	160	1019	2242	2.261	3.916	355	283	96.6	2.641375	736
WST315-1500-110	315S	1500	110	700	1540	2.242	3.883	352	196	96.3	3.785062	863
WST315-1500-132	315S	1500	132	840	1848	2.255	3.905	354	233	96.6	4.368637	920
WST315-1500-160	315S	1500	160	1019	2242	2.248	3.894	353	284	96.7	5.18774	996
WST315-1500-180	315M/L	1500	180	1146	2521	2.242	3.883	352	321	96.7	5.447107	1049
WST315-1500-200	315M/L	1500	200	1273	2801	2.261	3.916	355	354	96.7	5.771315	1078
WST315-1500-220	315M/L	1500	220	1401	3082	2.261	3.916	355	389	96.8	6.095523	1112
WST315-1500-250	315M/L	1500	250	1592	3502	2.236	3.872	351	447	96.8	6.808782	1181
WST315-1500-315	315M/L	1500	315	2006	4413	2.274	3.938	357	556	97.0	7.975931	1306

WST 系列 B3 外形安装尺寸图

71-132

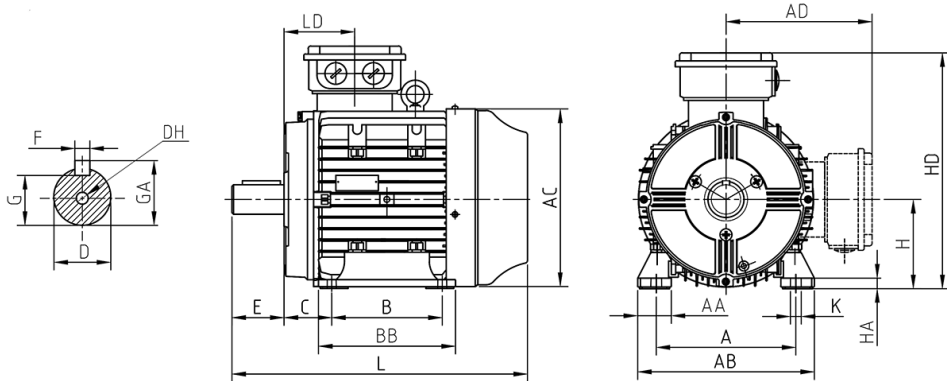

160-315

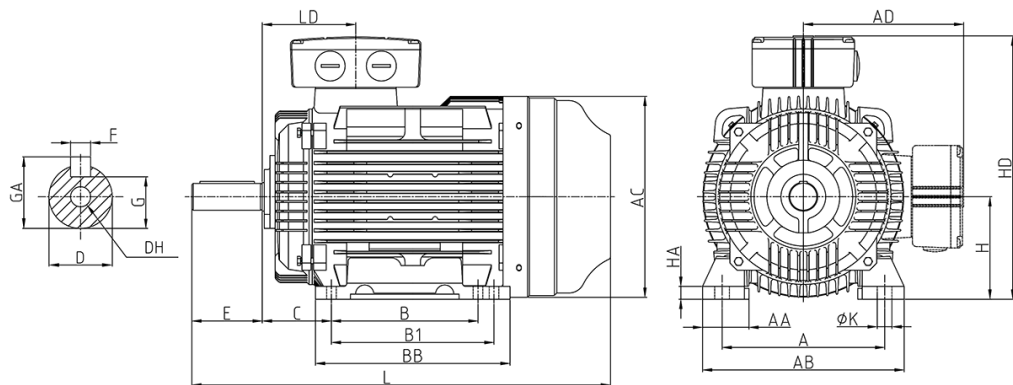

机座号	外形安装尺寸 (mm)																				
	A	B	B1	C	D	E	F	G	H	K	DH	GA	AA	AB	AC	AD	HA	HD	BB	LD	L
71	112	90	/	45	14	30	5	11	71	7	M5×13	16	27.5	136	137	107	10	178	110	66	247
90L	140	125	/	56	24	50	8	20	90	10	M8×20	27	37	180	175	141	10	231	153	87	324
112M	190	140	/	70	28	60	8	24	112	12	M10×22	31	47	230	222	167	12	279	170	85	381
132M	216	178	/	89	38	80	10	33	132	12	M12×28	41	54	264	260	191	15	323	210	129	463
160M	254	210	/	108	42	110	12	37	160	15	M16×36	45	64	315	314	244	20	404	260	146	610
160L	254	254	/	108	42	110	12	37	160	15	M16×36	45	64	315	314	244	20	404	304	146	654
180M	279	241	/	121	48	110	14	42.5	180	15	M16×36	51.5	68	351	355	264	22	444	311	161	684
180L	279	279	/	121	48	110	14	42.5	180	15	M16×36	51.5	68	351	355	264	22	444	349	161	722
200L	318	305	/	133	55	110	16	49	200	19	M20×42	59	70	388	397	296	25	496	369	186	774
225M	356	311	/	149	60	140	18	53	225	19	M20×42	64	79	430	445	319	28	544	386	189	846
250S/M	406	311	349	168	65	140	18	58	250	24	M20×42	69	97	484	484	370	32	620	445	208	911
280M	457	419	/	190	75	140	20	67.5	280	24	M20×42	79.5	85	542	546	400	35	680	536	217	1016
315S	508	406	/	216	80	170	22	71	315	28	M20×46	85	120	628	620	502	45	817	570	257	1231
315M/L	508	457	508	216	80	170	22	71	315	28	M20×46	85	120	628	620	502	45	817	680	257	1341

WST 系列 B35 外形安装尺寸图

71-132

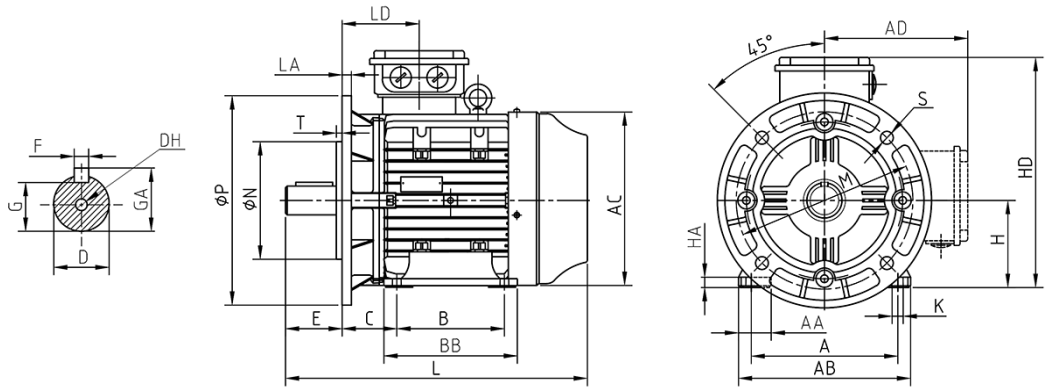

160-315

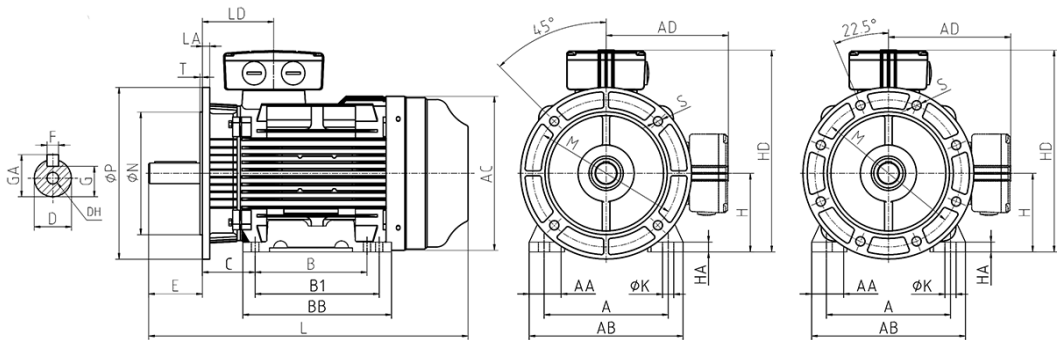

机座号	外形安装尺寸 (mm)																										
	A	B	B1	C	D	E	F	G	H	K	M	N	P	S	T	DH	GA	AA	AB	AC	AD	HA	HD	BB	LA	LD	L
71	112	90	/	45	14	30	5	11	71	7	130	110	160	4-Φ10	3.5	M5×13	16	27.5	136	137	107	10	178	110	9	66	247
90L	140	125	/	56	24	50	8	20	90	10	165	130	200	4-Φ12	3.5	M8×20	27	37	180	175	141	10	231	153	10	87	324
112M	190	140	/	70	28	60	8	24	112	12	215	180	250	4-Φ14.5	4	M10×22	31	47	230	222	167	12	279	170	12	85	381
132M	216	178	/	89	38	80	10	33	132	12	265	230	300	4-Φ14.5	4	M12×28	41	54	264	260	191	15	323	210	14	129	463
160M	254	210	/	108	42	110	12	37	160	15	300	250	350	4-Φ19	5	M16×36	45	64	315	314	244	20	404	260	15	146	610
160L	254	254	/	108	42	110	12	37	160	15	300	250	350	4-Φ19	5	M16×36	45	64	315	314	244	20	404	304	15	146	654
180M	279	241	/	121	48	110	14	42.5	180	15	300	250	350	4-Φ19	5	M16×36	51.5	68	351	355	264	22	444	311	15	161	684
180L	279	279	/	121	48	110	14	42.5	180	15	300	250	350	4-Φ19	5	M16×36	51.5	68	351	355	264	22	444	349	15	161	722
200L	318	305	/	133	55	110	16	49	200	19	350	300	400	4-Φ19	5	M20×42	59	70	388	397	296	25	496	369	17	186	774
225M	356	311	/	149	60	140	18	53	225	19	400	350	450	8-Φ19	5	M20×42	64	79	430	445	319	28	544	386	20	189	846
250S/M	406	311	349	168	65	140	18	58	250	24	500	450	550	8-Φ19	5	M20×42	69	97	484	484	370	32	620	445	22	208	911
280M	457	419	/	190	75	140	20	67.5	280	24	500	450	550	8-Φ19	5	M20×42	79.5	85	542	546	400	35	680	536	22	217	1016
315S	508	406	/	216	80	170	22	71	315	28	600	550	660	8-Φ24	6	M20×46	85	120	628	620	502	45	817	570	22	257	1231
315M/L	508	457	508	216	80	170	22	71	315	28	600	550	660	8-Φ24	6	M20×46	85	120	628	620	502	45	817	680	22	257	1341

WST 系列 B5 外形安装尺寸图

71-132

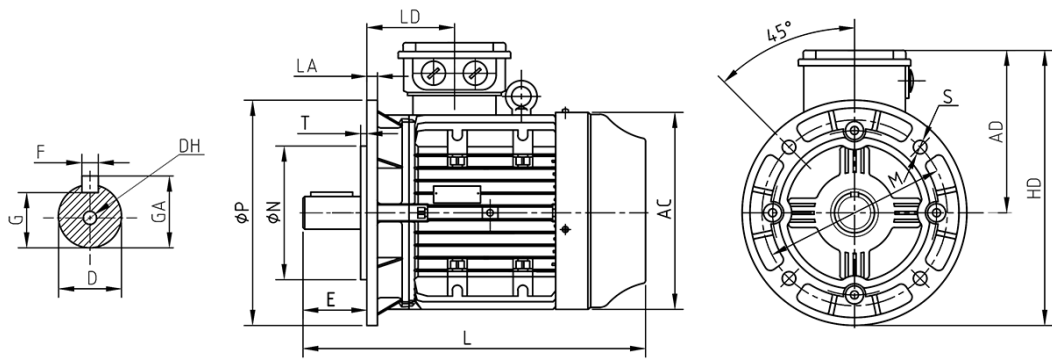

160-315

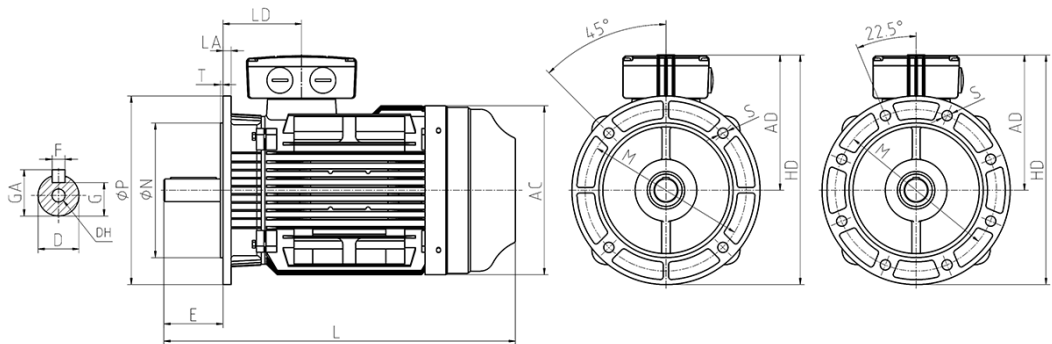

机座号	外形安装尺寸 (mm)																
	D	E	F	G	M	N	P	S	T	DH	GA	AC	AD	HD	LA	LD	L
71	14	30	5	11	130	110	160	4-Φ10	3.5	M5×13	16	137	107	187	9	66	247
90L	24	50	8	20	165	130	200	4-Φ12	3.5	M8×20	27	175	141	241	10	87	324
112M	28	60	8	24	215	180	250	4-Φ14.5	4	M10×22	31	222	167	292	12	85	381
132M	38	80	10	33	265	230	300	4-Φ14.5	4	M12×28	41	260	191	343	14	129	463
160M	42	110	12	37	300	250	350	4-Φ19	5	M16×36	45	314	244	419	15	146	610
160L	42	110	12	37	300	250	350	4-Φ19	5	M16×36	45	314	244	419	15	146	654
180M	48	110	14	42.5	300	250	350	4-Φ19	5	M16×36	51.5	355	264	439	15	161	684
180L	48	110	14	42.5	300	250	350	4-Φ19	5	M16×36	51.5	355	264	439	15	161	722
200L	55	110	16	49	350	300	400	4-Φ19	5	M20×42	59	397	296	496	17	186	774
225M	60	140	18	53	400	350	450	8-Φ19	5	M20×42	64	445	319	544	20	189	846
250S/M	65	140	18	58	500	450	550	8-Φ19	5	M20×42	69	484	370	645	22	208	911
280M	75	140	20	67.5	500	450	550	8-Φ19	5	M20×42	79.5	546	400	675	22	217	1016

WST 系列 V1 外形安装尺寸图

71-132

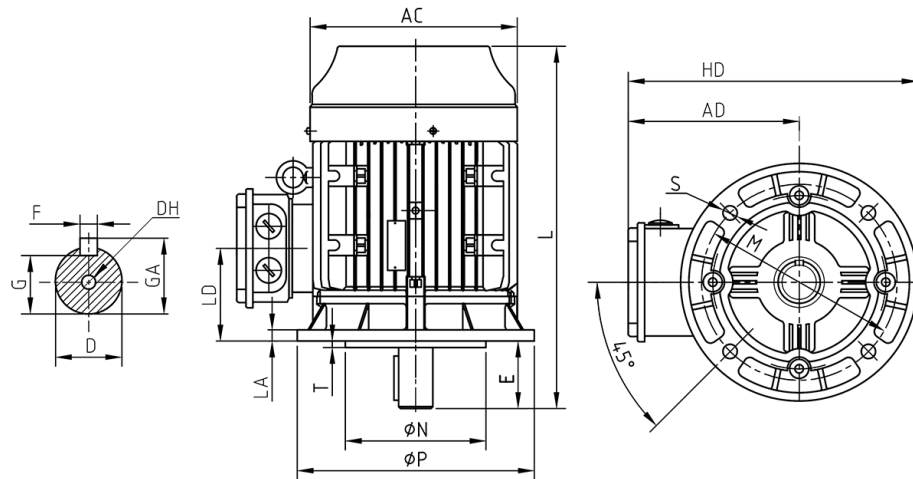

160-315

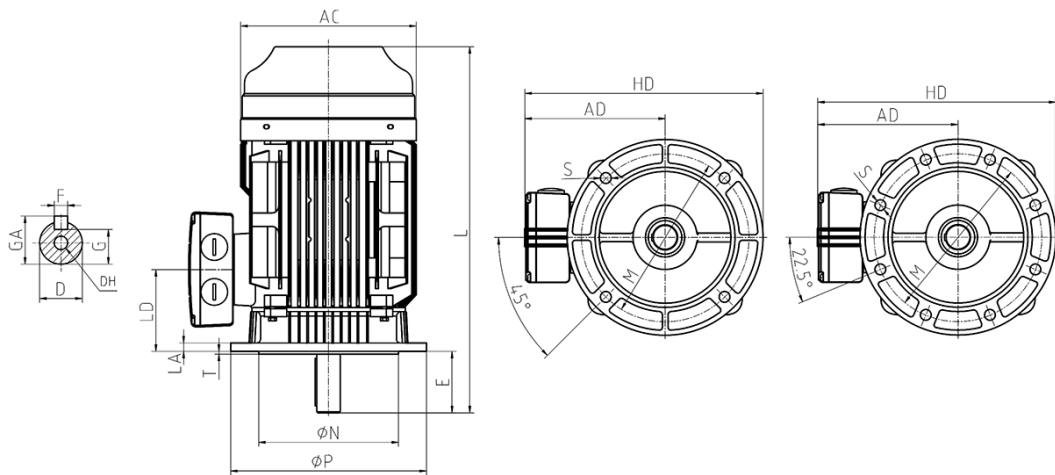

机座号	外形安装尺寸 (mm)																
	D	E	F	G	M	N	P	S	T	DH	GA	AC	AD	HD	LA	LD	L
71	14	30	5	11	130	110	160	4-Φ10	3.5	M5×13	16	137	107	187	9	66	247
90L	24	50	8	20	165	130	200	4-Φ12	3.5	M8×20	27	175	141	241	10	87	324
112M	28	60	8	24	215	180	250	4-Φ14.5	4	M10×22	31	222	167	292	12	85	381
132M	38	80	10	33	265	230	300	4-Φ14.5	4	M12×28	41	260	191	343	14	129	463
160M	42	110	12	37	300	250	350	4-Φ19	5	M16×36	45	314	244	419	15	146	610
160L	42	110	12	37	300	250	350	4-Φ19	5	M16×36	45	314	244	419	15	146	654
180M	48	110	14	42.5	300	250	350	4-Φ19	5	M16×36	51.5	355	264	439	15	161	684
180L	48	110	14	42.5	300	250	350	4-Φ19	5	M16×36	51.5	355	264	439	15	161	722
200L	55	110	16	49	350	300	400	4-Φ19	5	M20×42	59	397	296	496	17	186	774
225M	60	140	18	53	400	350	450	8-Φ19	5	M20×42	64	445	319	544	20	189	846
250S/M	65	140	18	58	500	450	550	8-Φ19	5	M20×42	69	484	370	645	22	208	911
280M	75	140	20	67.5	500	450	550	8-Φ19	5	M20×42	79.5	546	400	675	22	217	1016
315S	80	170	22	71	600	550	660	8-Φ24	6	M20×46	85	620	502	832	22	257	1231
315M/L	80	170	22	71	600	550	660	8-Φ24	6	M20×46	85	620	502	832	22	257	1341

WST 系列 B14 外形安装尺寸图

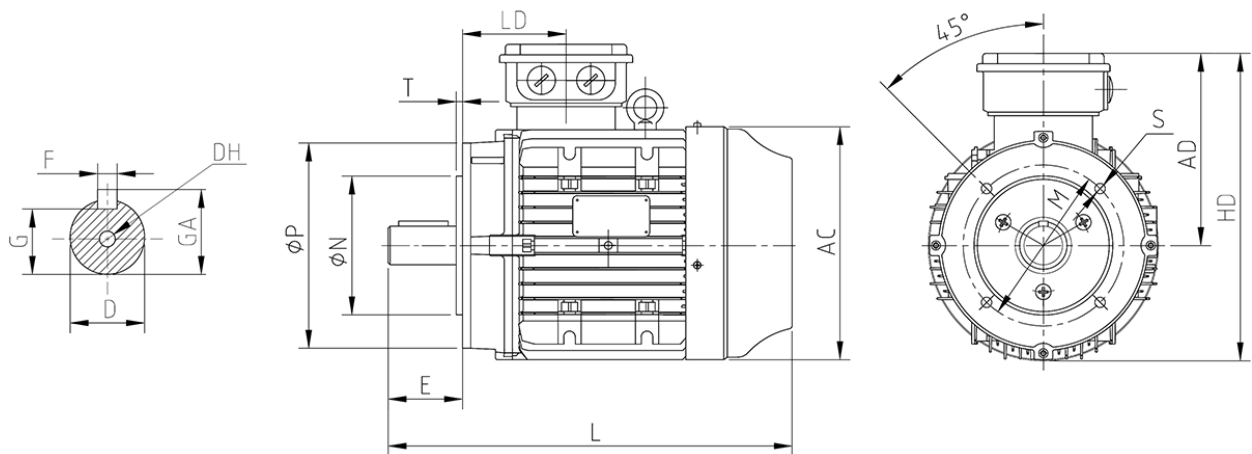

机座号	外形安装尺寸 (mm)															
	D	E	F	G	M	N	P	S	T	DH	GA	AC	AD	HD	LD	L
71	14	30	5	11	85	70	105	M6	2.5	M5×13	16	137	107	178	66	247
90L	24	50	8	20	115	95	140	M8	3	M8×20	27	175	141	231	87	324
112M	28	60	8	24	130	110	160	M8	3.5	M10×22	31	222	167	279	85	381
132M	38	80	10	33	165	130	220	M10	3.5	M12×28	41	260	191	323	129	463

WST 系列 B34 外形安装尺寸图

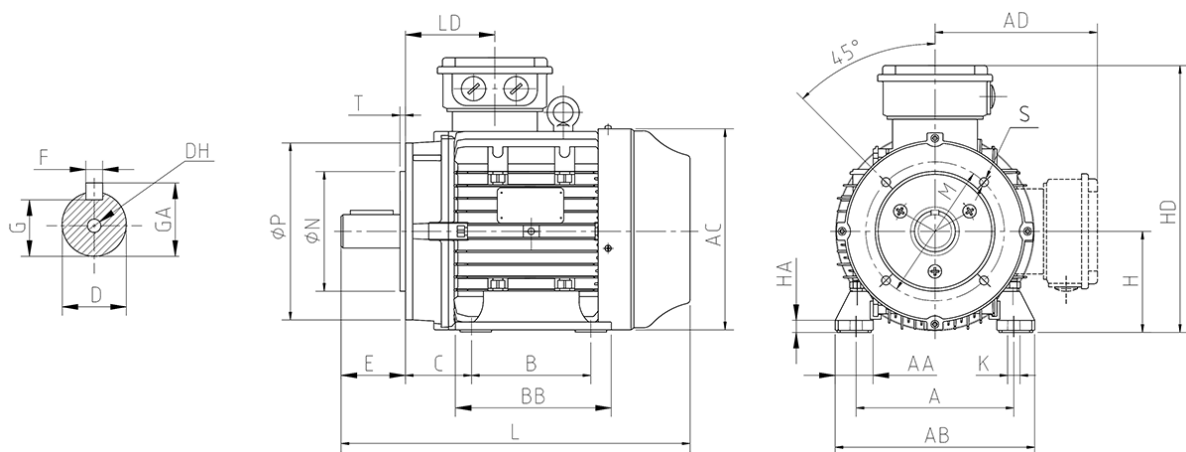

机座号	外形安装尺寸 (mm)																								
	A	B	C	D	E	F	G	H	K	M	N	P	S	T	DH	GA	AA	AB	AC	AD	HA	HD	BB	LD	L
71	112	90	45	14	30	5	11	71	7	85	70	105	M6	2.5	M5×13	16	27.5	136	137	107	10	178	110	66	247
90L	140	125	56	24	50	8	20	90	10	115	95	140	M8	3	M8×20	27	37	180	175	141	10	231	153	87	324
112M	190	140	70	28	60	8	24	112	12	130	110	160	M8	3.5	M10×22	31	47	230	222	167	12	279	170	85	381
132M	216	178	89	38	80	10	33	132	12	165	130	220	M10	3.5	M12×28	41	54	264	260	191	15	323	210	129	463

WST 系列轴承及接线盒

机座号	轴承		接线盒	
	轴伸端	非轴伸端	纹孔数与直径 M (mm)	外形尺寸 (mm)
71	6202-ZZ	6202-ZZ	2-M20x1.5	103x103x38
90	6205-ZZ/C3	6204-ZZ/C3	2-M25x1.5	115x115x54
112	6306-ZZ/C3	6205-ZZ/C3	2-M25x1.5	115x115x54
132	6308-ZZ/C3	6206-ZZ/C3	2-M32x1.5	138x138x57
160	6309/C3	6209/C3	2-M40x1.5	200x160x80
180	6311/C3	6211/C3	2-M40x1.5	200x160x80
200	6312/C3	6212/C3	2-M50x1.5	250x200x92
225	6313/C3	6312/C3	2-M50x1.5	250x200x92
250	6315/C3	6313/C3	2-M63x1.5	340x210x106
280	6317/C3	6314/C3	2-M63x1.5	340x210x106
315	6319/C3/NU319	6319/C3/7319B(V1)	2-M63x1.5	413x258x165

WONDER 萬德

始于1988

福州万德电气有限公司

地址：福建省福州市经济开发区长安投资区长洋路 120 号

企业网站：www.wonderfz.com

企业邮箱：wonder@wonderfz.com

联系电话：0591-83998899

企业传真：0591-83998666

福建万达电机有限公司

地址：福建省福安电机电器工业区兴达路 239 号

企业网站：www.wonder-cn.com

企业邮箱：wonder@dayu-casting.com

联系电话：0593-6379666 6379988

企业传真：0593-6379999

上海普莱德机电科技有限公司

地址：上海市虹口区新建路 203 号底层 2308 室

企业邮箱：shpld@126.com

联系电话：021-65355573

企业传真：021-65460669

万德电气马来西亚公司

地址：No.11, Jalan Meranti Jaya 16, Taman Meranti Jaya
Industrial Park, 47120 Puchong, Selangor, Malaysia

企业邮箱：sales@wonderelectric.com.my

联系电话：+603-8063-9399

万德电气新加坡公司

地址：No. 111, Neythal Road, Singapore, 628598

企业邮箱：wondersg@singnet.com.sg

联系电话：+65-6265-8698